

Reg. No. :

--	--	--	--	--	--	--	--	--	--	--	--	--	--	--	--	--	--	--	--

**Question Paper Code : 41378**

B.E./B.Tech. DEGREE EXAMINATIONS, NOVEMBER/DECEMBER 2024

Third/Fourth Semester

Mechanical Engineering

ME 3491 – THEORY OF MACHINES

(Common to : Mechanical Engineering (Sandwich)/Mechanical and Automation Engineering/Agricultural Engineering)

(Regulations 2021)

Time : Three hours

Maximum : 100 marks

(Use of A3 Drawing Sheet is permitted)

Answer ALL questions.

PART A — (10 × 2 = 20 marks)

1. Define : Kinematic link and Kinematic pair.
2. What is degree of freedom of a mechanism? How it is determined?
3. What is pressure line and pressure angle of a gear?
4. What is meant by compound epicyclic gear?
5. Define the terms co-efficient of friction and limiting angle of friction.
6. State the laws of solid dry friction.
7. Mention the conditions for a body to be in equilibrium under the action of two forces, three forces and a torque.
8. State D'Alembert's principle.
9. "Two masses in different planes are necessary to rectify the dynamic unbalance". Give your comment on this statement.
10. Give two examples of free and forced vibrations.

PART B — (5 × 13 = 65 marks)

11. (a) A horizontal bar 1.5 meters long and of small cross-section rotates about vertical axis through one end. It accelerates uniformly from 1200 rpm to 1500 rpm in an interval of 5 seconds. What is the linear velocity at the beginning and end of the interval? What are the normal and tangential components of the acceleration of the mid-point of the bar after 5 seconds after the acceleration begins.

Or

- (b) Draw the profile of a cam in which the follower.
- (i) is moved outwards through 30 mm during  $180^\circ$  of cam rotation with cycloidal motion.
  - (ii) dwells for  $20^\circ$  of the cam rotation
  - (iii) returns with uniform velocity during the remaining  $160^\circ$  of the cam rotation.

The base circle diameter of the CAM is 28 mm and the roller diameter is 8 mm. The axis of the follower is offset by 6 mm to the left. What will be the maximum velocity and acceleration of the follower during the outstroke if the cam rotates at 1500 rpm counter – clockwise?

12. (a) The following data relate to two spiral gears in mesh.

Shaft angle =  $90^\circ$

Centre distance = 160 mm (approx.)

Normal circular pitch = 8 mm

Gear ratio = 3

Friction angle =  $5^\circ$

For maximum efficiency of the drive, determine the

- (i) Spiral angle of the teeth (3)
- (ii) Number of teeth (3)
- (iii) Centre distance (exact) (3)
- (iv) Pitch diameters (4)

Or

(b) An epicyclic gear train is shown in figure. 1. The number of teeth on  $A$  and  $B$  are 80 and 200 respectively. Determine the speed of the arm ' $a$ '

(i) If  $A$  rotates at 100 rpm clockwise and  $B$  at 50 rpm counter-clockwise. (7)

(ii) If  $A$  rotates at 100 rpm clockwise and  $B$  is stationary. (6)

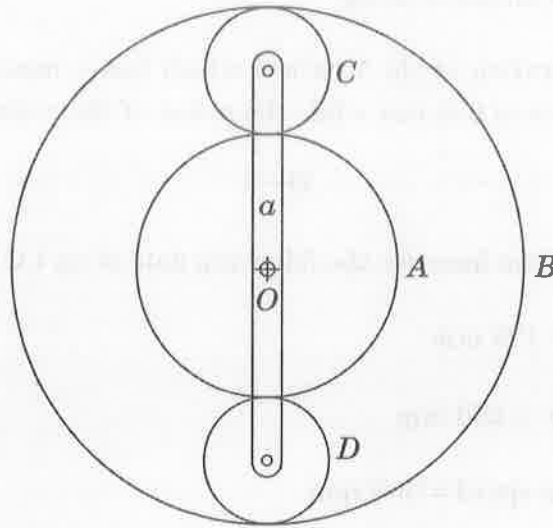

Figure 1.

13. (a) The cutting speed of a broaching machine is 9 m/min. The cutter of the machine is pulled by a square-threaded screw with a nominal diameter of 60 mm and pitch 12 mm. The operating nut takes an axial load of 500 N on a flat surface of 80 mm external diameter and 48 mm internal diameter. Determine the power required to rotate the operating nut. Take  $\mu = 0.14$  for all contact surface on the nut.

Or

(b) A single plate clutch is required to transmit 8 kW at 1000 rpm. The axial pressure is limited to 70 kN/m<sup>2</sup>. The mean radius of the plate is 4.5 times the radial width of the friction surface. If both the sides of the plate are effective and the coefficient of friction is 0.25, find the

(i) Inner and the outer radii of the plate and mean radius. (6)

(ii) Width of the friction lining. (7)

14. (a) A horizontal gas engine running at 210 rpm has a bore of 220 mm and a stroke of 440 mm, the connecting rod is 924 mm long and the reciprocating parts weigh 20 kg when the crank has turned through an angle of  $30^\circ$  from the inner dead centre, the gas pressure on the piston is  $500 \text{ kN/m}^2$  respectively. Diameter of the piston rod is 40 mm. Determine.

(i) Turning moment on the crank shaft (4)

(ii) Thrust on the bearing (4)

(iii) Acceleration of the flywheel which has a mass 8 kg and radius of gyration of 600 mm while the power of the engine is 22 kW. (5)

Or

(b) Find the inertia force for the following data of an I.C. engine.

- Bore = 175 mm
- Stroke = 200 mm
- Engine speed = 500 rpm
- Length of the connecting rod = 400 mm
- Crank angle =  $60^\circ$  from T.D.C and
- Mass of reciprocating parts = 180 kg.

15. (a) A shaft supported in bearing that are 1.6 m apart projects 400 mm beyond bearings at each end. It carries three pulleys one at each end and one at the centre of its length. The masses of the end pulleys are 40 kg and 22 kg and their centre of mass are at 12 mm and 18 mm respectively from the shaft axes. The mass of the centre pulley is 38 kg and its centre of mass is 15 mm from the shaft axis. The pulleys are arranged in a manner that they give static balance. Determine the

(i) relative angular positions of the pulleys. (6)

(ii) dynamic forces developed on the bearings when the shaft rotates at 210 rpm. (7)

Or

- (b) The measurements on a mechanical vibrating system show that it has a mass of 8 kg and that the springs can be combined to give an equivalent spring of stiffness 5.4 N/mm. If the vibrating system have a dashpot attached which exerts a force of 40 N when mass has a velocity of 1 m/s, find
- critical damping coefficient. (3)
  - damping factor (3)
  - logarithmic decrement (3)
  - ratio of two consecutive amplitudes (4)

PART C — (1 × 15 = 15 marks)

16. (a) The simple band brake, as shown in figure 2 is applied to a shaft carrying a flywheel of mass 400 kg, the radius of gyration of the flywheel is 450 mm and runs at 300 rpm. If the coefficient of friction is 0.2 and the brake drum diameter is 240 mm find
- The torque applied due to a hand load of 100 N. (5)
  - The number of turns of the wheel before it is brought to rest and (5)
  - The time required to bring it to rest from the moment of the application of the brake. (5)

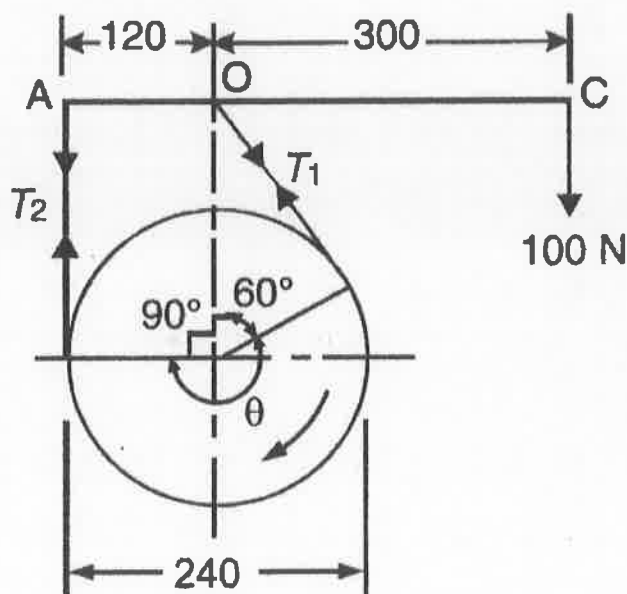

All dimensions in mm.

Figure 2.

Or

